

PROCESS PLATFORM: MILLENNIUM® M-2010 SERIES

ULTRA HIGH-SPEED, HIGH ACCURACY IN-LINE SMT DISPENSING SYSTEM

The Millennium® M-2010 dispensing system delivers unparalleled high speed and accuracy for today's most demanding applications. For surface mount adhesive dispensing, the M-2010 system is ideal for high-volume, production-critical applications that must be sustained 24 hours per day, 7 days per week with minimal operator intervention.

Configured with the patented DJ-2100 DispenseJet® non-contact valve, the M-2010 system's fast-motion acceleration (2 g peak) optimally delivers industry-standard surface amount adhesives at rates in excess of 50,000 dots per hour. Non-contact jetting eliminates the need for a mechanical needle standoff, and is unaffected by variations in PCB surfaces. It reduces time spent programming standoff locations, as well as time between assistance. Board support is unnecessary, as is routine replacement of valve needles due to wear.

The DV-7000 Heli-flow™ pump provides fast, repeatable dispensing of medium- to high-viscosity fluids and pastes using industry-standard fixed mechanical standoff nozzles and a floating head for light touch contact with the substrate. Typical applications include small-dot dispensing of dispensable-grade solder pastes, silver epoxy, and surface mount adhesives. Quick-release mounting brackets provide easy changeover between applications.

Optimal delivery of a wide range of surface mount adhesives and solder pastes can be achieved with CADImport software used in conjunction with Asymtek's exclusive Fluidmove® for Windows NT® (FmNT) software. With the CADImport utility, Fluidmove programs can quickly and efficiently be developed offline using existing CAD-generated data, or a file from a component placement machine.

The high-performance M-2010 system incorporates field-proven Millennium process control of fluid delivery and software-managed temperature control. With its precision dispensing valves and advanced lighting options, the M-2010 system will meet your most demanding requirements.

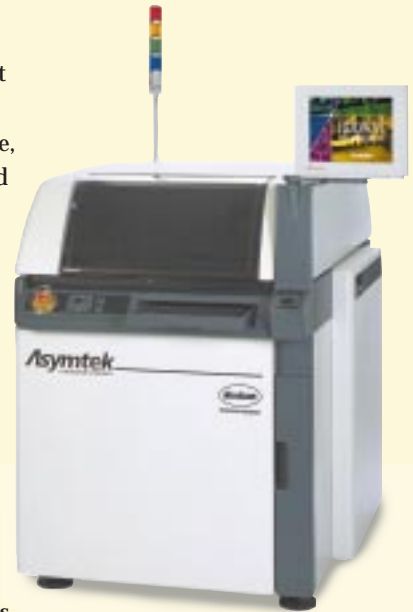

FEATURES

- Proven dispense speeds of surface mount adhesives in excess of 50,000 dots per hour using the DispenseJet valve
- The DV-7000 Heli-flow™ pump provides fast, accurate dispensing of medium- to high-viscosity fluids and solder pastes
- Fast-motion acceleration (2 g peak), with up to 1 m/s X-Y velocity for high throughput with ± 0.025 mm repeatability
- Compact footprint (1.65 m²) conserves factory floor space
- SMEMA-compatible Multimove Conveyor software module conveys parts simultaneously, not sequentially, enhancing throughput
- Improved throughput using pipelined fiducials
- Data-driven, offline programming with CADImport software
- Network interface card included allows connection to a local Ethernet network
- SEMI-S2 compliant, ergonomic flat-panel display and integrated keyboard

M-2010 SYSTEM SPECIFICATIONS:

MOTION SYSTEM:

Type:	Low-inertia, closed-loop, high-resolution linear encoder, brushless DC servo motor XYZ positioner
Encoder Resolution:	5 micrometers
X-Y Acceleration:	2.0 g peak with S-curve jerk control
X-Y-Z Velocity:	1 m/s (40 in./s)
X-Y-Z Positioning Accuracy:	±0.07 mm (0.003 in.), 3 sigma
X-Y Repeatability:	±0.025 mm (0.001 in.)
Z Travel:	78 mm (3.1 in.)

DISPENSE AREA:

DJ-2100 DispenseJet® Valve:	474 x 565 mm (18.7 x 22.2 in.)
DV-7000 Heli-flow™ Pump:	466 x 565 mm (18.3 x 22.2 in.)

DISPENSE SPEED:

For Surface Mount Adhesives (SMA):	In excess of 50,000 dots per hour; 0.5 mm (22 mil) or larger dots on 3 mm grid
------------------------------------	--

VISION AND LIGHTING:

Vision:	Cognex® or ITI, automatic Pattern Recognition System allows for optical registration of the work piece to reliably locate dispensing sites in both surface mount adhesive and solder paste dispense operations (can compensate for up to 7° rotational misalignment of part)
Lighting:	On-axis LED through lens (standard), Moritex (optional)

CONVEYOR:

Edge-belt style conveyors; can convey parts up to 565 mm (22.2 in.) maximum width
SMEMA-compatible conveyor

COMPUTER:

Computer:	Pentium®-based PC
User Interface:	Color TFT flat-panel display ASCII keyboard with integrated storage drawer Integrated system trackball Network interface card (Twisted pair Ethernet support)
Networking Option:	

SOFTWARE:

User Environment:	Fluidmove® for Windows NT® CADImport Software Program
Operating System:	Windows NT
Software Options:	SECS/GEM Interface

FLUID DELIVERY METHOD:

DJ-2100 DispenseJet® Valve
DV-7000 Heli-flow™ Pump

FACILITIES REQUIREMENTS:

System Footprint:	See illustration
Air Supply:	621 kPa (6.1 atm., 90 psi) 1 CFM standard, up to 5 CFM for some configurations (28 liters/min = 1 CFM)
Power (Mains):	Note: This is an adaptive power supply; it can accommodate supply voltages between 185 – 265 VAC. Typical U.S. is 230 VAC, single phase, 30A. Also automatically accommodates 50-60 Hz
System Weight:	476 kg (1,050 lbs.)
Standards Compliance:	SEMI-S2 SEMI-S8 SMEMA CE

OTHER STANDARD FEATURES:

Jet valve heat
Vacuum purge station

OPTIONAL FEATURES:

Integrated under-board support system
Dual-action Dispensing Head:
For sequential dispensing of both SMA and solder paste, using the DJ-2100 DispenseJet valve and the DV-7000 Heli-flow pump; or two of either the DJ-2100 DispenseJet valve or DV-7000 Heli-flow pump (see note below)
Needle heater

*Other options are available.
Contact us for further information.*

Please contact these locations for the name of your local representative.

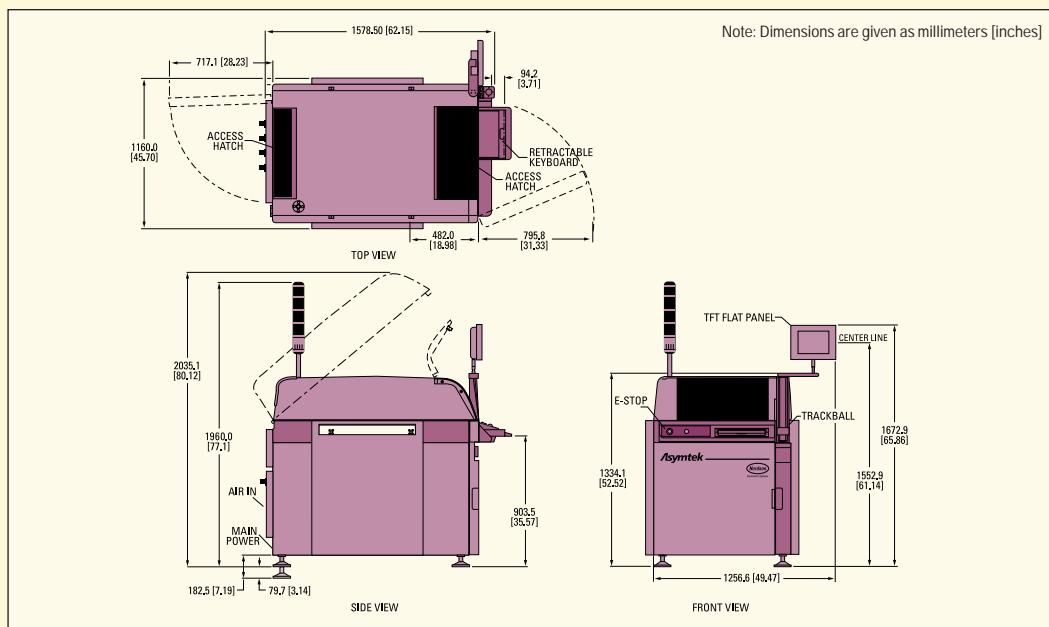

HEADQUARTERS

2762 Loker Avenue West
Carlsbad, CA 92008-6603 USA
U.S. (toll free): 1-800-ASYMTEK
Tel: (760) 431-1919
Fax: (760) 431-2678
Email: info@asymtek.com

INTERNATIONAL SALES

Europe: +31 (0) 43-352-4466
Japan: +81 (0) 3-5762-2801
Korea: +82-347-766-8321
S.E. Asia: +65 (0) 7782511
Taiwan: +886-2-82001268

Web Site: www.asymtek.com

Fluidmove®, DispenseJet®, Millennium®, Heli-flow®, and Asymtek® are trademarks of Asymtek.
Nordson® is a trademark of Nordson Corporation.
Windows NT® is a registered trademark of Microsoft, Inc.
Pentium® is a registered trademark of Intel.

Cognex® is a registered trademark of Cognex, Inc.

Asymtek reserves the right to make design changes to products to improve their function. These changes may occur between printings.

Note: A system configured with a dual-action dispensing head will have a reduced dispense area due to the offsets between the valves and camera. Contact Asymtek for your specific application requirements.