

XPM²-series Reflow Soldering System

model	dim A	dim B
520	3620 (138.50")	2780 (109.50")
730	4430 (174.50")	3700 (145.50")
820	4430 (174.50")	3700 (145.50")
1030	5350 (210.50")	4610 (181.50")
1240	6260 (246.50")	5520 (217.50")

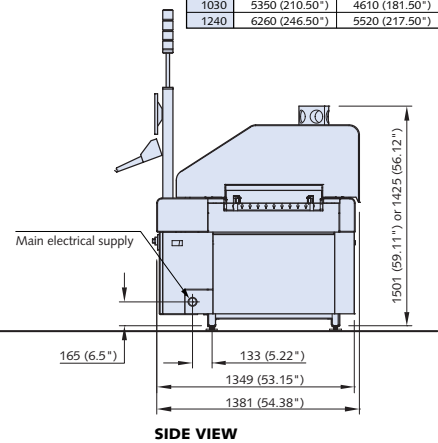
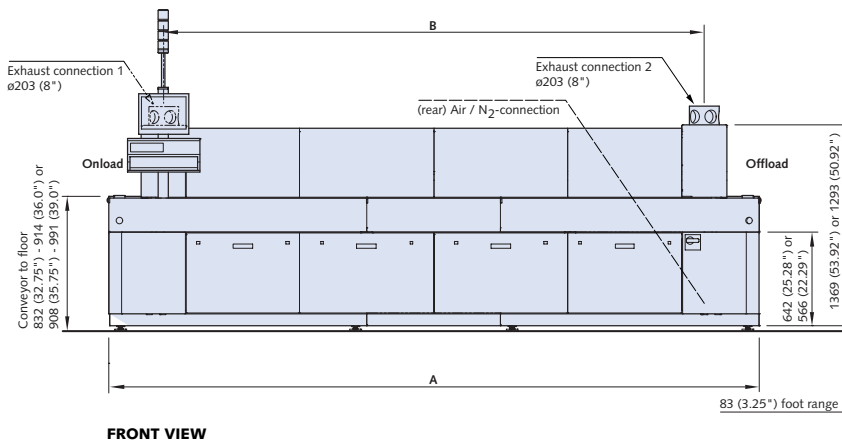

Technical specifications

Standard

- Top and Bottom Convection Heating and Cooling
- 350°C maximum operating temperature for Lead-Free processing
- 20" Belt Conveyor
- Heavy Duty Frame
- Individual Cell Inlet and Exhaust™
- Flux Flow Control™
- OCS Oven Control Software
- HIS Host Interface Software
- "How do I ...?" Help Software
- Windows™ Operating System
- DELL PC, Flat Panel Display and Keyboard
- Precision Profiling™
- Powered Hood Lifts
- Over-Temperature Safety System

Options

- 24" Belt Conveyor
- 22" Combination Edge-Rail and Belt Conveyor
- Parking Center Support Conveyor
- Computer Controlled Rail Width Adjust
- Computer Controlled Edge-Rail Lubrication
- Polar Cooling™
- Controlled Cooling
- Basic N₂ Package
- True N₂ / AIR Switching
- Multiple Atmosphere Sampling Ports
- OEM Integrated Oxygen Analyzer
- Low N₂ Package
- N₂ Conservation Package
- O₂ Doping
- Cell Blower Speed Control
- Integrated Exhaust Stack Filter
- SMEMA Equipment Interface

Vitronics Soltec

A DOVER COMPANY

Europe
VITRONICS SOLTEC BV
 Karolusstraat 20
 4903 RJ Oosterhout
 the Netherlands
 tel. +31-162-483000
 fax +31-162-483253
 e-mail: info@nl.vitronics-soltec.com

Germany
VITRONICS SOLTEC GmbH
 An der Köhlerei 7
 97828 Marktheidenfeld
 Germany
 tel. +49-9391-988-2-0
 fax +49-9391-988-2-28
 e-mail: info@de.vitronics-soltec.com

Americas
VITRONICS SOLTEC Inc.
 2 Marin Way
 Stratham, NH 03885
 New Hampshire, U.S.A.
 tel. +1-603-772-7778
 fax +1-603-772-9340
 e-mail: info@us.vitronics-soltec.com

Asia Pacific
VITRONICS SOLTEC PTE LTD.
 135 Joo Seng Road,
 #02-01 PM Industrial Building
 368363 Singapore
 tel. +65-6484-3010
 fax +65-6484-1910
 e-mail: info@sg.vitronics-soltec.com

China
VITRONICS SOLTEC Shanghai
 Room G, 14th Floor, Huadu Mansion
 828-838 ZhangYang Road
 200122 Shanghai, China
 tel. +86 21-6876-4885/4995
 fax +86 21-6876-5335
 e-mail: info@cn.vitronics-soltec.com

Korea
VITRONICS SOLTEC Korea
 Rm 1009 Chong-Gu Blueville,
 11-1 Sunae-Dong, Bundang-Gu
 463-825 Songnam, South Korea
 Tel +82-31-717-4791
 Fax +82-31-717-4792
 e-mail: info@kr.vitronics-soltec.com

Malaysia
VITRONICS SOLTEC Malaysia
 8-2-5 Sunny Point Complex,
 Jalan Sultan Azlan Shah, Batu Uban,
 11700 Penang, Malaysia.
 tel. +60-4-658-4227
 fax +60-4-655-4227
 e-mail: info@my.vitronics-soltec.com

Vitronics Soltec Training Program

Vitronics Soltec's technical centres in Singapore, the Netherlands and the United States offer various levels of customer training courses in soldering processes, equipment operation and maintenance. Vitronics Soltec also provides customers in-house training courses or hands-on process support to enhance both customer knowledge and soldering yields.

Easy Accessibility



INTEGRATED OXYGEN ANALYZER



AUTO LUBE SYSTEM

Vitronics Soltec maintains a constant program of product improvement which may effect design. We reserve the right to make these changes without prior notice or liability. Pentium™ is a registered trademark of Intel Corporation. Windows™ is a registered trademark of Microsoft Corporation.

art. nr. 39745B



All Vitronics Soltec equipment is designed to meet the European CE directives

www.vitronics-soltec.com



MAKE

THE RIGHT CONNECTION



XPM²-series
Reflow Soldering System
featuring Precision Profiling™

Vitronics Soltec
A DOVER COMPANY

MAKE THE RIGHT CONNECTION

Why

Vitronics Soltec?

The Vitronics Soltec XPM²-series represents a long line of thermal processing systems that have proven their capability worldwide and established a reputation for incredible reliability. Insightful engineering combined with intelligent programming consistently deliver thermal performance, process control and superior value in high production, 7-day, 24-hours-a-day environments.

Designed to handle current and emerging technologies, the Vitronics Soltec XPM²-series is capable of virtually unlimited process configurations - that can be changed quickly and precisely with no sacrifice to production schedules or diverse processing parameters.

There is no compromise with Vitronics Soltec XPM²-series. Just what you'd expect from Vitronics Soltec, the World Leader in Soldering Technology.



COMPUTER OPERATIONS AND INFORMATION CENTER



The Vitronics Soltec XPM²-series utilizes a Pentium™ computer/processor with Windows™ based software, a trackball, a keyboard and a flat panel display. Menu-driven VCP proprietary software offers maximum flexibility in a true multi-tasking environment. Operator point-and-click graphical interface displays all operating conditions. Process states are color-coded for easy reference. Using the computer interface, the customer can switch from air to nitrogen atmospheres without affecting thermal processing.

THE LOWEST COST OF OWNERSHIP

Vitronics Soltec XPM²-series delivers the lowest cost of ownership. XPM² offers a choice of air and nitrogen models with a unique atmospheric switching options.

COMPUTER-CONTROLLED CHAIN LUBRICATION SYSTEM

Our advanced automatic chain lubrication system eliminates the mess and maintenance associated with keeping edge rail chains in top operating condition. Software alerts the operator when the lubricant reservoir must be refilled.

The frequency of application is based on the number of chain revolutions. Lubrication cycles are programmable by the operator.

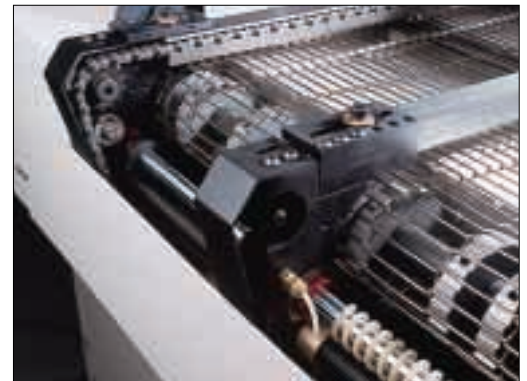

Computer-Controlled Chain Lubrication System



VITRONICS SOLTEC PATENTED GAS MANAGEMENT SYSTEM



- Leads the industry in thermal performance, providing uniformity and repeatability.
- Limits nitrogen consumption, reducing operating costs.
- Flux Flow Control™ removes flux contaminants from each zone, resulting in the cleanest heated tunnels in the industry, and virtually eliminating maintenance.

UNIQUE VITRONICS SOLTEC HEAT CELL DESIGN

The high mass quick response aluminum heater, cornerstone of Vitronics Soltec technology, acts as a thermal reservoir. By transmitting uniform heat directly to the PCB from the closest position possible, it produces outstanding uniformity and the highest levels of repeatability.

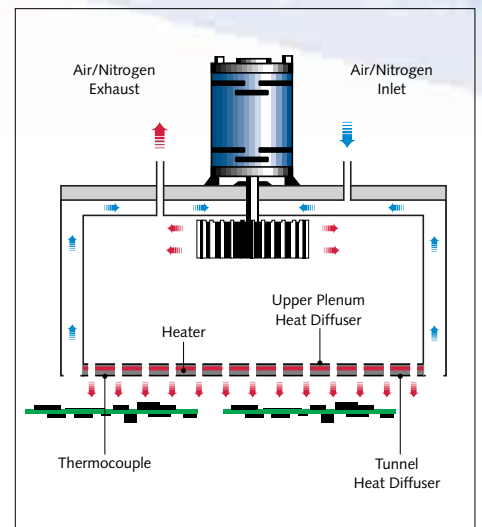

Exhaust and Inlet diagram



FLUX FLOW CONTROL™

Vitronics Soltec's Flux Flow Control™ feature puts an end to messy filters, tough cleaning problems, and their associated scheduled down-time and lost production. With Flux Flow Control™, flux vapors, PCB outgassing, and airborne contaminants - by-products of the reflow soldering process - are effectively managed and removed in inert or nitrogen atmosphere processing machines without wasting valuable inerting, and without the need for "in process" filters or cleaning. Additionally, flux vapors stay away from the cooling zone, so they don't condense on oven interior surfaces, or on processing PCBs.

An optional integrated exhaust stack filter will discharge clean gasses into the factory exhaust system. Filters are off the shelf type, and can be replaced without inhibiting the process.



Flux Flow Control™

POLAR COOLING TECHNOLOGY

Utilizing an advanced in-cell heat exchanger, a "direct to air" fully integrated heat rejection system, and cleanable heat exchangers in the cooling cells, the Vitronics Soltec XPM²-series is able to achieve dramatic cooling performance while maintaining low nitrogen consumption.

- Each Cooling Cell provides excellent cooling, controlling liquidous time.
- Heat extracted from the cooling cells is discharged directly into the machine exhaust, eliminating the need for an external chiller.
- Cleanable heat exchangers can be easily removed.
- Controlled Cooling doubles heat removal capacity and guarantees absolute liquidous time control.



Controlled Cooling Unit (option)